

BOWDENS

LINK BOX INDICATOR



LINK BOX INDICATOR FOR UNDERGROUND
DISTRIBUTION NETWORKS

enquiries@springltd.co

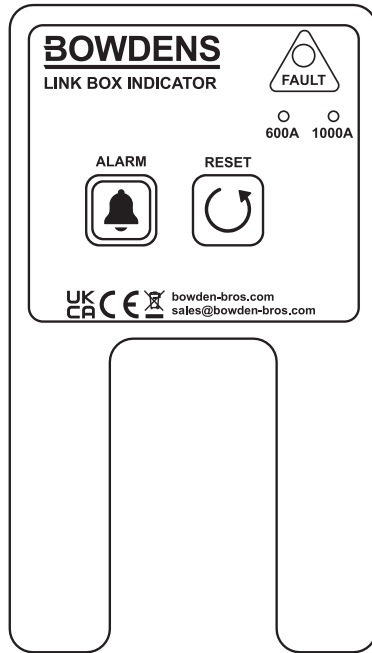

1.0 OVERVIEW

The Link Box Indicator allows the user to establish where the fault location is and which set of links needs to be removed to restore the electricity supply. Without a Link Box Indicator, this process can be demanding and time consuming.

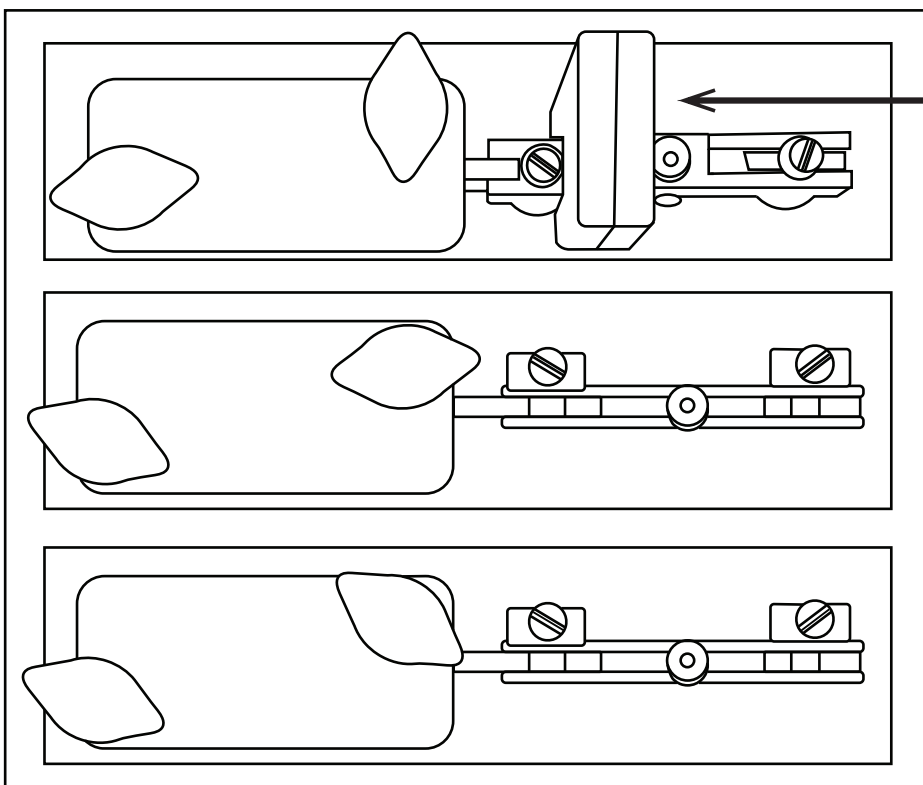

The Link Box Indicator positioned in a Link Box.

2.0 OPERATION

2.1 Fault detection and reset

The Link Box Indicator is permanently armed (ready to detect a fault).

Press 'ALARM' to put the unit into fault mode. The fault LED will blink twice to indicate 'ALARM' has been selected. The fault LED will flash every 10 seconds (approximately).

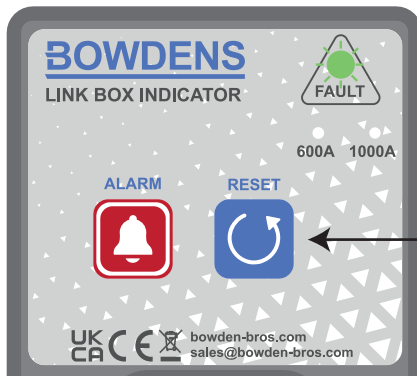
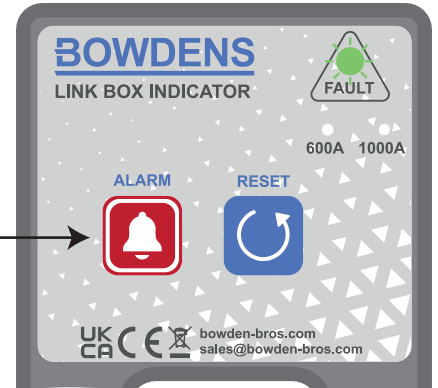

Press 'RESET' to reset a fault. The fault LED will blink once (if in alarm) to indicate 'RESET' has been selected. The unit will then go back into the armed state.

The unit can be configured for approximate trip levels of 600A or 1000A. Press both buttons together to toggle between 600A and 1000A.

The units are set to 1000A by default.

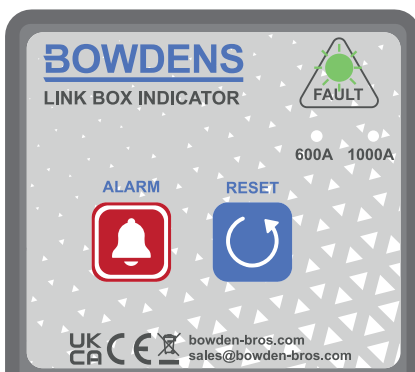
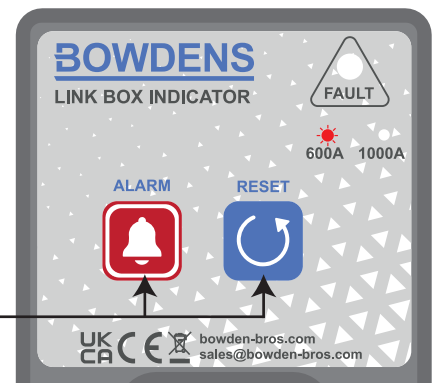

If the unit detects a fault above the set trip level the unit will enter the ALARM state by blinking the fault LED twice and thereafter blinking once every 10 seconds approximately.

The unit will complete a timed reset after approximately six hours. (Operators can reset before this time by pressing the 'RESET' button).

Note 1: You need to press the buttons quite firmly.

Note 2: Trip levels may be affected by installation and type of Link fitted as this changes the proximity to the Link Box Indicator sensing circuit. Always ensure the Indicator is fitted at 90° to the link bar and where possible that the link is positioned centrally between the Indicator's prongs.

2.2 Low battery detection

If the unit is in alarm mode, the first press of 'RESET' will reset the alarm, with a green flash.

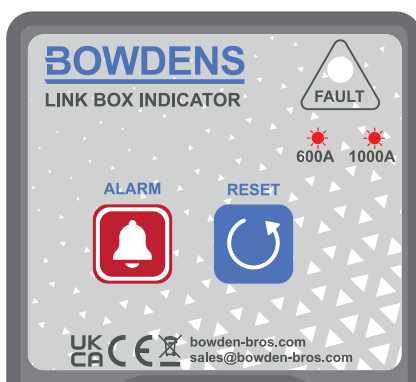
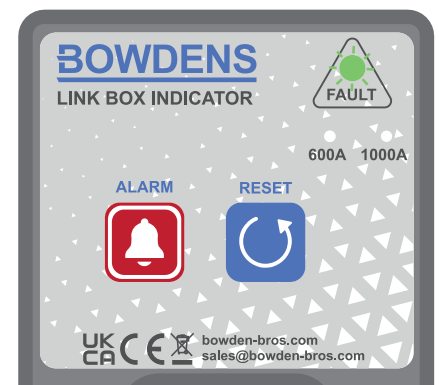

If the unit is not in alarm mode, pressing 'RESET' will test the battery. The two red LEDs will flash red just once if the battery is OK. Alternatively, the unit will flash the two red LEDs 10 times to signify that the battery is low.

3.0 SPECIFICATION

Operating Temperature:	-10 to 70°C
Irreparable Damage to Battery:	>85°C
Estimated Battery Life:	10 Years*
Battery Type:	Lithium Thionyl Chloride (Li-SOCl ₂) 3.6V 2.1Ah
Accuracy:	+/-25% of Selected Trip Level
Trip Time:	0.5-1.0 Cycles (10-20ms)

* Dependent on environmental conditions. Excessively hot or excessively cold temperatures will shorten the battery life below the estimated value.

4.0 DIMENSIONS

