

BOWDENS

OMEGA III EFI

BOW OMIII LV E

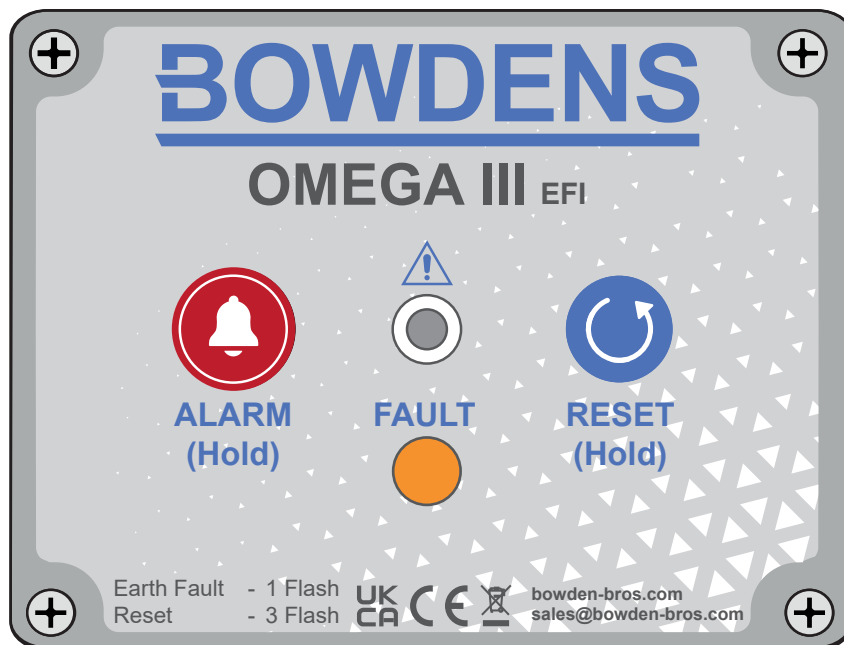

**EARTH FAULT INDICATOR FOR UNDERGROUND
CABLE NETWORKS**

enquiries@springltd.co

1.0 OVERVIEW

The Omega III EFI is an HV fault indicator designed to locate earth faults on cable networks with high accuracy and integrity. It will flash a bright red LED as well as rotate the flag indicator to red under fault condition. It will reset automatically on a timed reset, or by restoration of the LV supply or, from a remote reset control signal or by operation of the reset button. The Omega III consists of a small polycarbonate box, which is fully water spray and dust proof to IP65. The electronic circuit board within the module is coated using a micro film process to provide protection from weather and environmental conditions when installed externally. The EFI is fully EMC tested to ensure compliance with the required standards for the UK CA and CE mark. It is also tested for power frequency magnetic fields, for stability in a field at 5000Amps/metre, an onerous test to EN61000-4-8 to ensure perfect immunity to high magnetic fields during fault conditions. Fault detection is derived from a remote core balance CT located either around the three phase incoming cable (as long as there is an insulated gland between the cable and the switchgear) or within the dry cable termination box (see 6.0).

2.0 OPERATION

ROTARY SWITCH USER SETTABLE VALUES

TRIP THRESHOLDS

Fault current on the cable network generates a proportional voltage at the CT secondary output, which if above a pre-set threshold will trigger the processor. This starts a trip delay during which any signals are suppressed. This is to allow magnetising inrush or capacitive currents on the HV network to dissipate. Once this trip delay (nominal 40msecs) is over, the EFI will respond to any current above the pre-set trip threshold, and will start the bright red LED flashing, and flip the flag indicator. The trip level and the trip delay are user settable between the values given below by rotating the actuator SW5 (trip level) and SW6 (trip delay). The timed reset is set using SW4 (reset time).

SW 4 - Reset time: select the time in hours before the EFI resets to the alert state.

0	1	2	3	4	5	6	7	8	9
No Reset	3 hours	4 hours	5 hours	6 hours	7 hours	8 hours	9 hours	10 hours	12 hours

SW5 - Trip level: select the earth fault trip level in Amps.

0	1	2	3	4	5	6	7	8	9
40 Amps	60 Amps	70 Amps	100 Amps	110 Amps	130 Amps	150 Amps	170 Amps	190 Amps	230 Amps

SW 6 - Trip delay/detection time: select the number of 50 Hz cycles required before the EFI confirms fault current.

0	1	2	3	4	5	6	7	8	9
2 cyls	3 cyls	4 cyls	5 cyls	6 cyls	7 cyls	8 cyls	9 cyls	10 cyls	10 cyls

RESET : LV RESET - MANUAL - REMOTE - TIMED

There are four methods of resetting the relay:

1. LV reset: the Omega III will reset when the local LV source is re-energised ie. restoration of supply. The LED will flash three times and then cancel, the flag indicator will return to black, and the output relay will return to normal state. Note: This reset time can take up to two minutes.
2. Manual reset: there are two manual buttons on the front face of the relay, one to put the unit into alarm and another to reset the alarm.
3. Remote reset: an external signal between 6 – 30V ac or dc can be applied to the reset terminals for a minimum of 10 secs.
4. Timed reset: in case the local LV supply is off for a sustained period, the EFI will reset in 12 hours if the internal battery is fully charged. If it is not fully charged (one hour charge time), the EFI will reset, but the flag indicator will remain red to indicate that the internal battery requires a charge following the fault condition. The flag will reset when the LV power is returned.

OUTPUT RELAY

The Omega III EFI incorporates a two pole changeover output relay brought out to two sets of terminal connectors, which provide volt free contacts for an external telecoms interface (Normally Open, Common, Normally Closed). The EFI incorporates our multi-detect feature, which means the relay will respond to fault current when the instrument trips, but then will reset nine seconds later. The LED will remain flashing and the flag indicator will be set to red, but the output relay is ready to respond to subsequent faults. If connected to an RTU, it will indicate for the first, second, third, etc detection of fault current on the cable. Contacts are rated at 110V dc / 125V ac. 1 amp. 30 watt maximum.

MANUAL BUTTONS

Press the ALARM button. The red LED will flash once and then every four seconds. The flag indicator will turn from black to red. Press and hold the RESET button for approx three seconds, the red LED will flash three times before resetting.

REMOTE LED INDICATOR (Option)

The Omega III has the facility to drive a remote LED which will then flash in unison with the LED on the relay. This is connected to the remote LED indicator connector.

REMOTE RESET (Option)

The Omega III can be reset remotely using a signal from an RTU. The reset signal needs to be 6V to 30V ac or dc and applied for 10 seconds. The signal is connected using the remote reset connector.

3.0 POWER SUPPLY

The Omega III EFI can be powered from an LV power source. This is a 230Vac 50Hz to 9Vac transformer located in the back box of the EFI, where the output is connected to the LV input terminals of the Omega III PCB. It has a two way screw terminal connector on the transformer assembly. Power is connected to this terminal via one of the four M12 glands using 0.5mm² mains flex from the local LV supply. The LV transformer will power the EFI and charge the internal battery, which powers the unit during fault conditions when the LV source is not present. DIP switch 4 **MUST** be set to **ON**.

LV Supply - With Transformer

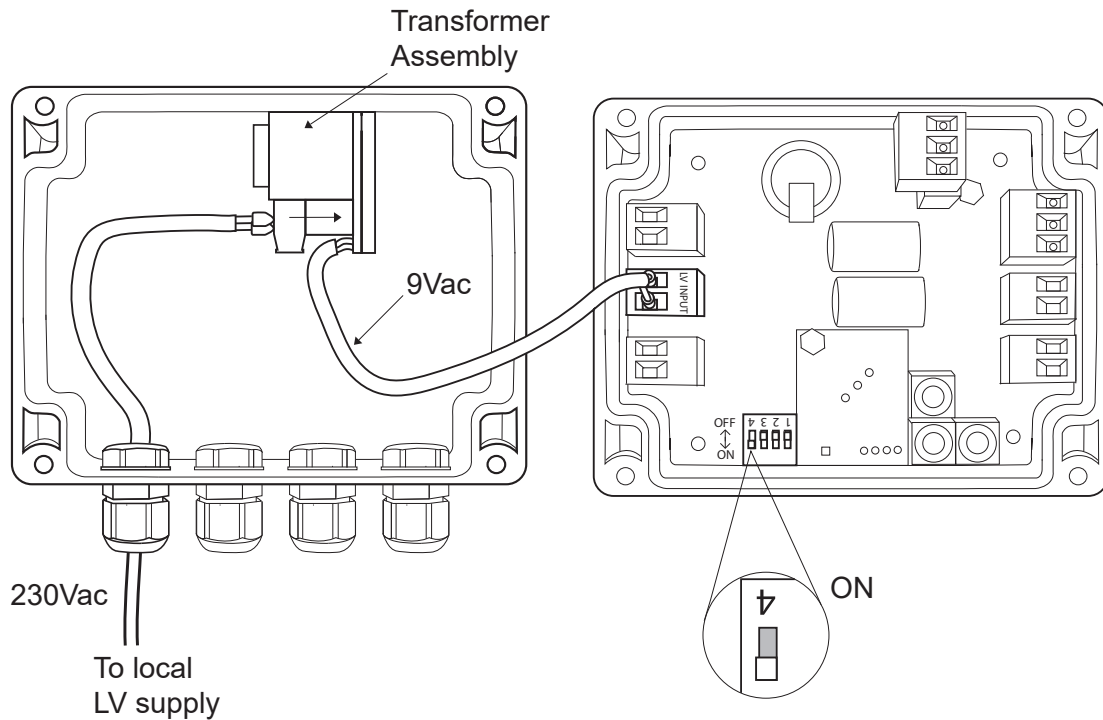

Battery Supply

The Omega III EFI can be powered from a 3.6V lithium battery (non-rechargeable). This is connected to the battery connector.

NOTE: It is important to observe the correct polarity. DIP switch 4 **MUST** be set to **OFF**.

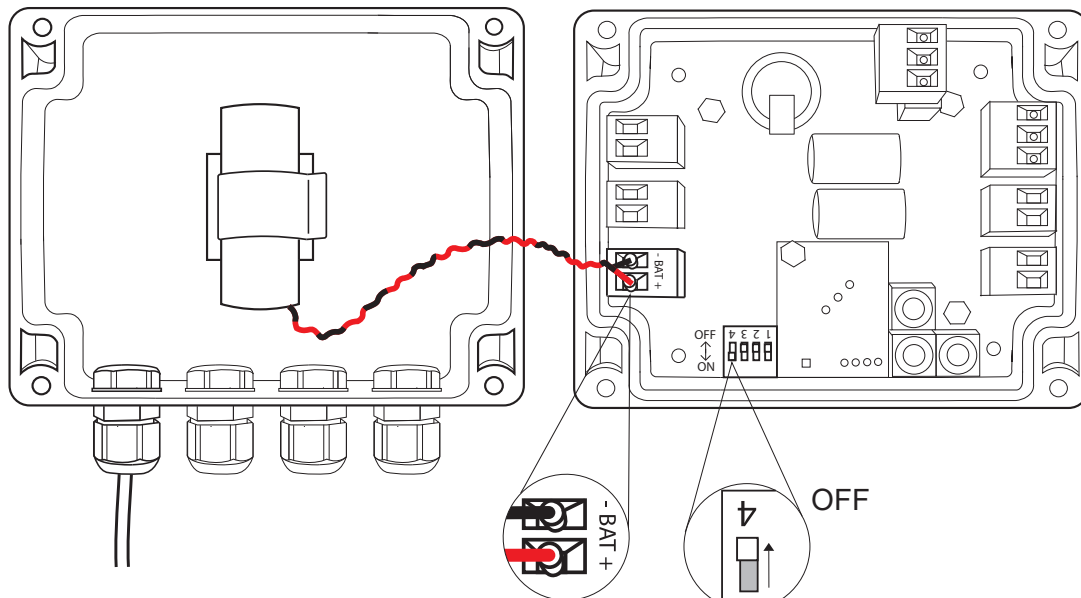

4.0 CONNECTIONS

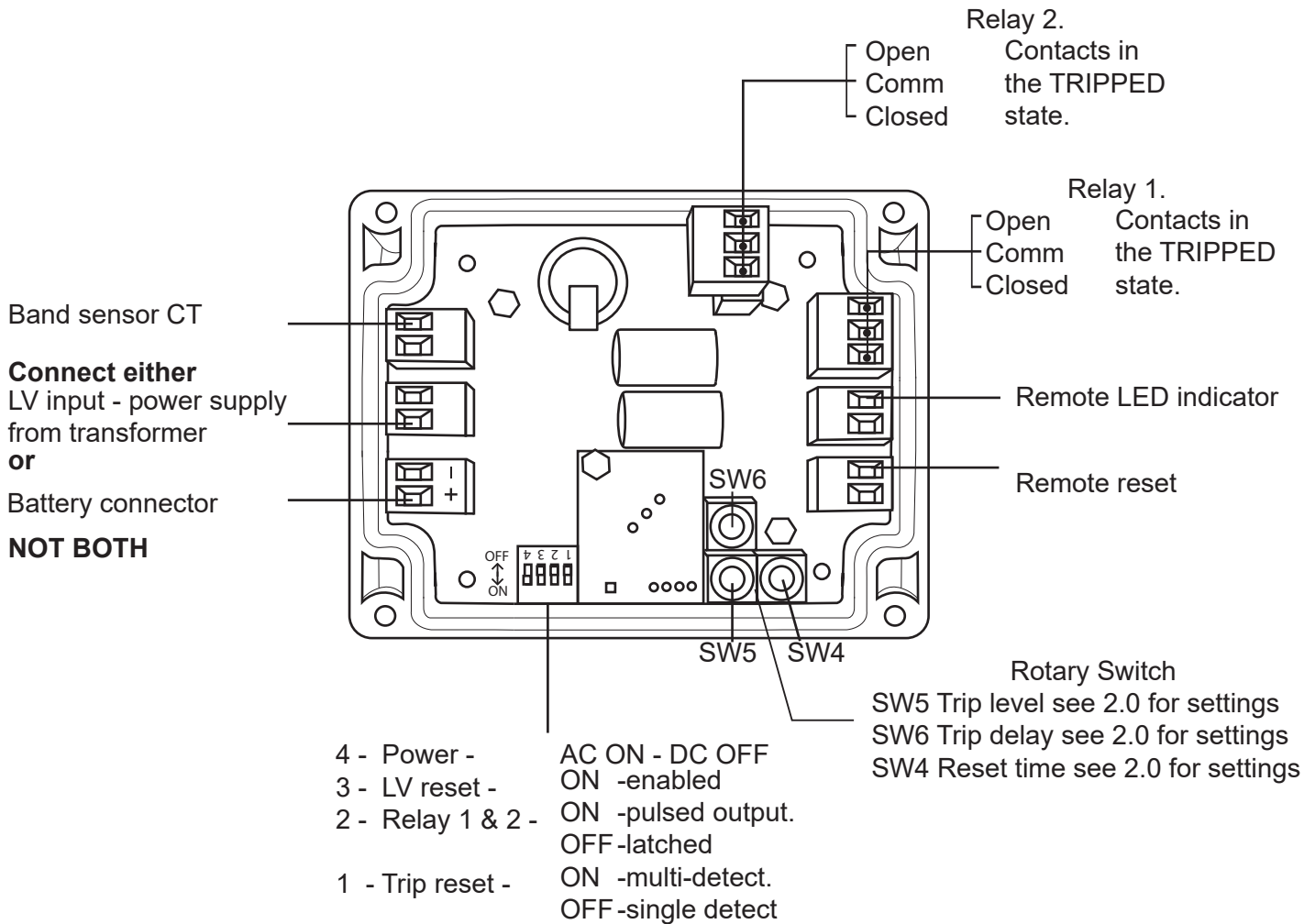

5.0 TESTING OF INSTALLATION

The complete EFI installation should be tested following installation, and at service intervals to ensure correct operation. Bowdens manufacture a mobile injection tester that makes this task easy. For a trip level of 40A (set by SW5), the test cable can be wrapped around the C/T generating 10 Amps per turn, so with five turns the EFI should trip at 50 Amps, but not on three turns for 30 Amps. The tester delivers the current for a time > 40msecs to test the trip delay. The relay can be tested using the manual ALARM button, and can also be RESET.

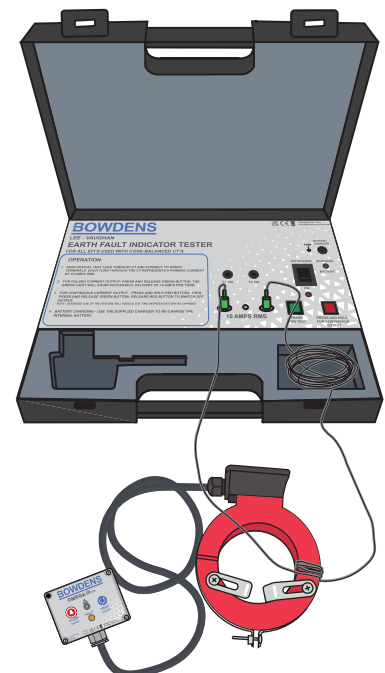

6.0 CURRENT TRANSFORMER INSTALLATION

The Omega EFI is compatible with both standard 60:1 ratio cast resin core balance C/Ts, or the Bowdens band sensor C/T, both of which can be installed externally on the incoming cable, or within the dry cable termination box. The earthing requirements must be observed to allow any sheath current to be cancelled by returning the earth path back through the C/T (see diagrams).

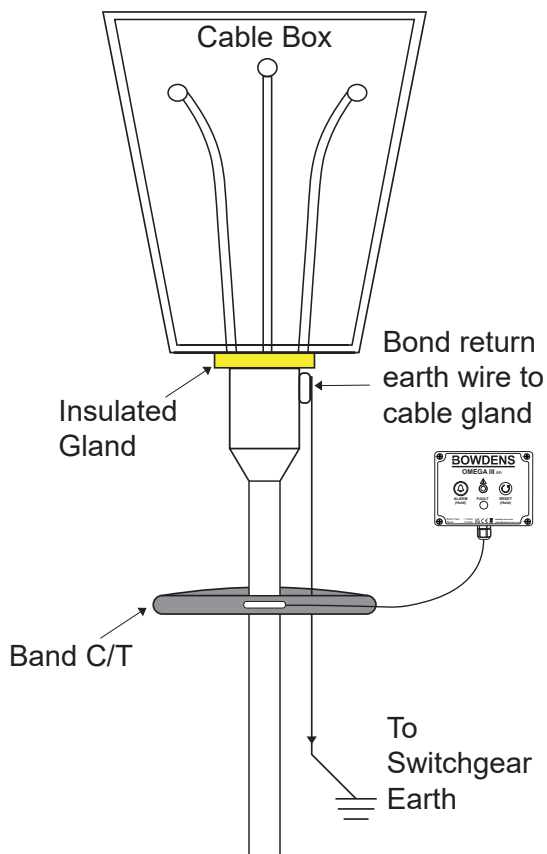

External Band Current Transformer

Traditional external cast resin C/T installation. Insulated gland at entry to cable box. An earth braid needs to be soldered to the earth termination and brought back through the C/T to cancel the earth fault flowing in the cable sheath.

The sheath earth terminates at the insulated gland and so the C/T can be installed in the base of the cable box where it will detect only out of balance current caused by an earth fault flowing in one phase.

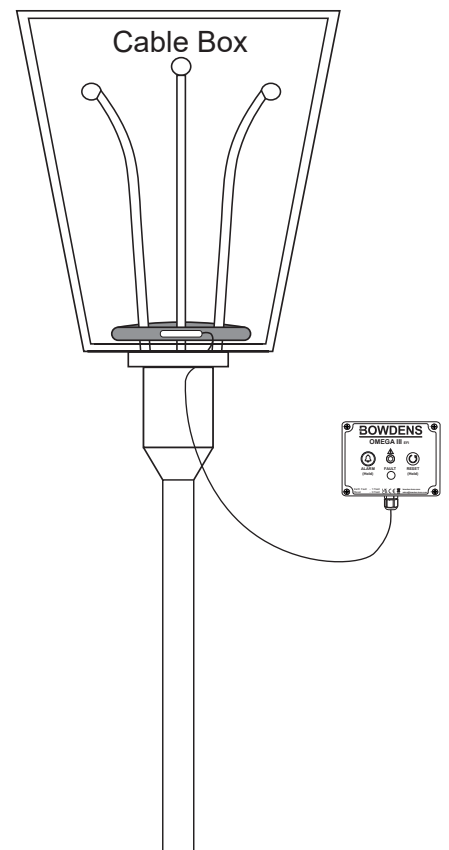

Band Current Transformer in Dry Cable Box

CT SELECTION

BAND SENSOR C/T

The 1000:1 ratio C/T is encapsulated in a flexible polyolefin tubing with a thermoplastic adhesive inner liner. The inner liner melts when the material is shrunk to seal and encapsulate the internal components of the band C/T, thus offering environmental protection. The polyolefin tubing has an operating temperature range of -55°C to $+85^{\circ}\text{C}$ and performs well on exposure to UV. The flexible band sensor C/T can be produced up to 1.3 metres in length, so it can be used to encompass three phase conductors (see BAND C/T diagram) within the cable box, making it very adaptable.

BAND CT - A 1000:1 split core C/T in polyolefin tubing.

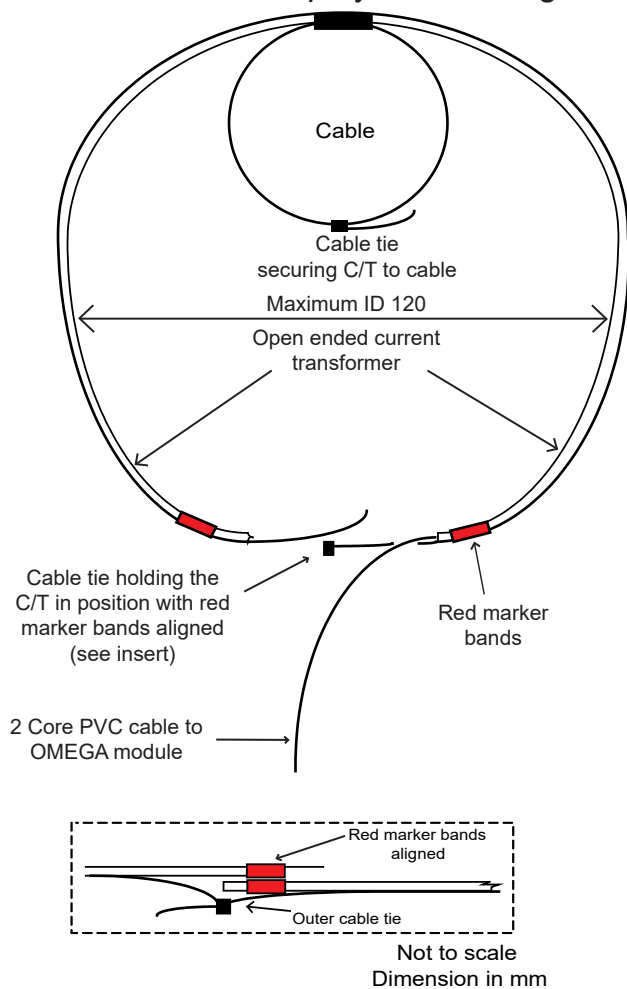

CAST RESIN SPLIT CORE C/T - A 60:1 ratio split or solid core C/T can also be used and mounted on the incoming cable, but must have a burden resistor across the input of the C/T. Consult Bowdens for the resistor value.

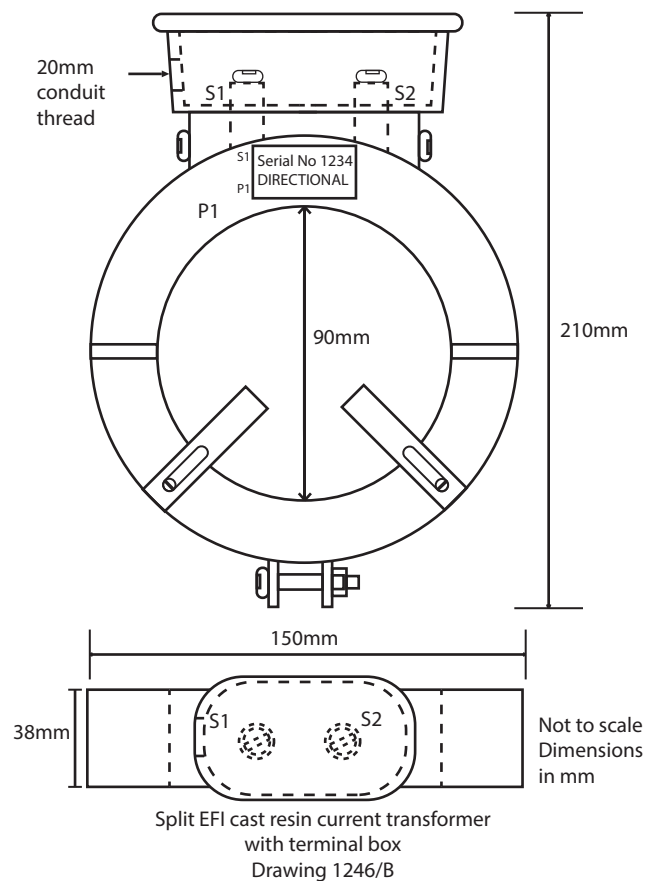

7.0 TYPE TESTING

7.1 Electro Magnetic Compatibility

Emissions

1.1.1 EN 55 022: Radiated Emission Limits

1.1.2 EN 55 022: Conducted Emission Limits

1.1.3 EN 61000-3-2 Harmonic Values and Limits of Harmonics

1.1.4 EN 61000-3-3 Voltage Fluctuations

1.2 Immunity EN 61 326

1.2.1 EN 61000-4-2: Electrostatic Discharge

1.2.2 EN 61000-4-3 Radiated Immunity Testing

1.2.3 EN 61000-4-4 Fast Transients

1.2.3 EN 61000-4-5 Surge Immunity

1.2.3.5 EN 61000-4-6 Immunity to conducted radio frequency above 9kHz

1.2.4 EN 61000-4-11 Voltage Dips, Short Interruptions and Voltage Variations

7.2 Low Voltage Directive

Council Directive 2014/35EU.

7.3 Power Frequency Magnetic Field

Immunity to EN 61000-4-8 referencing procedure: MAG-01B

7.4 Short Circuit Testing

Immunity to maximum voltage at C/T input on saturation of C/T

7.5 Environmental

Enclosure testing to IP65 with additional accelerated tests to freeze/thaw cycle, humidity and saltspray.

7.6 Temperature Testing:

Temperature cycle testing between -20°C to +70°C.

8.0 ROUTINE TESTING

Functional testing is carried out on 100% of all manufactured units before shipping.

9.0 SPECIFICATION

Indication:	Bright red LED and mechanical flag black/red
Trip Level:	User selectable between 40 Amps and 200 Amps +/- 5%
Trip Delay:	Pre-set at 40msecs nominal
Reset Time:	Pre-set at 12 hours +/- 10 mins
Output relay:	Two pole changeover relay - common / NO / NC for each pole. Contact rating: 110V dc / 125V ac. 1 Amp. 30 Watt maximum.
Reset Signal:	6 to 30Vac or Vdc applied for 10 secs.
Temperature Range:	-20°C to +70°C
Enclosure:	Polycarbonate – IP65

10.0 MOUNTING DATA

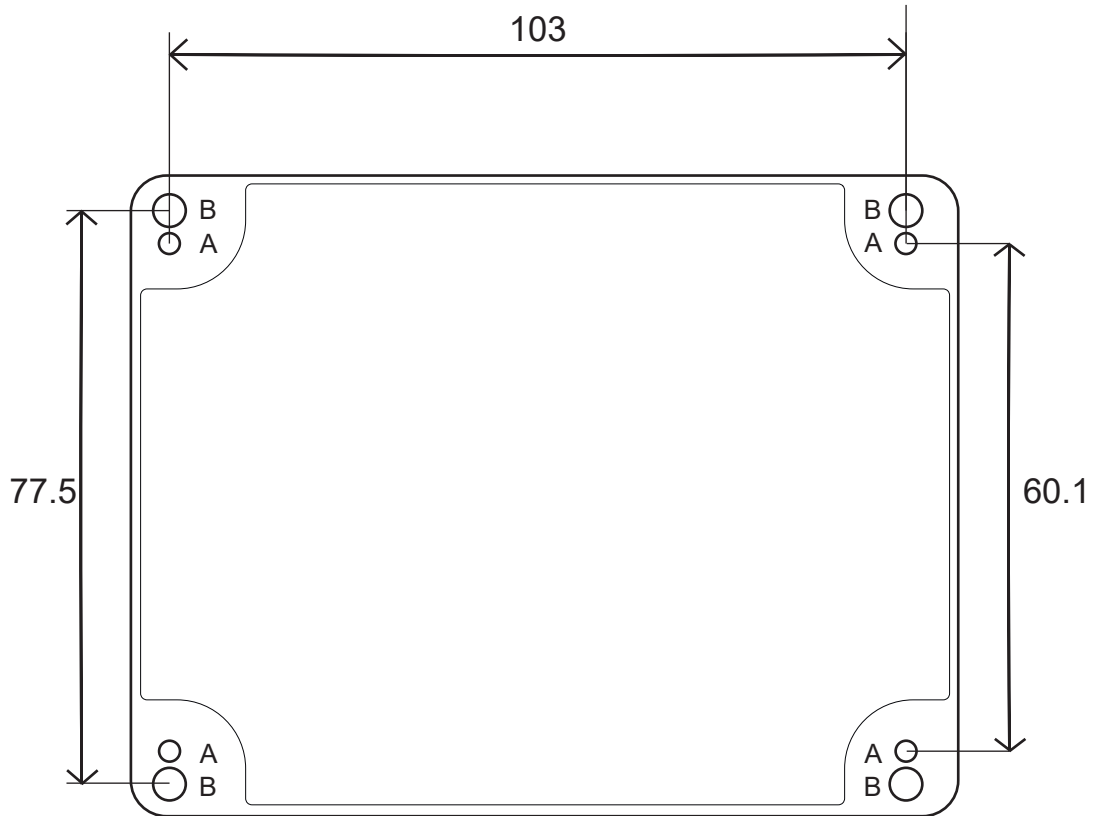

HOLES A
Corner fillet holes for fixing OMEGA base
Holes 4mm diameter
Distances between centres
Dimensions in mm
Not to scale

HOLES B
Recessed screw holes for securing OMEGA front panel



Please consider the environment at the end of this product's life.
At end of life please take this unit to your closest electrical recycling point or return this unit to Spring (Europe) Limited for recycling.
Recycle Responsibly
ISO14001

VERSION 1.1

RELEASE 08.09.25

ECO Reference	Date
ECO0261	28.05.25
ECO0371	08.09.25