

BOWDENS

PATHFINDER 360 ALPHA 2G & 4G



PERMANENTLY INSTALLED POLE MOUNTED OVERHEAD
LINE FPI WITH LOCAL INDICATION AND INTEGRAL
COMMUNICATIONS FOR ALARMS & CONTROL

1.0 OVERVIEW

The Pathfinder 360 Alpha is an inductive overhead line Fault Passage Indicator, designed to be installed on the pole three metres below the conductors, that senses an out of balance electro-magnetic field in a single or three phase, solidly earthed HV network at between 6 to 36KV (or equivalent voltages). It will sense both phase to phase and earth faults of values down to a nominal 7 Amps, sensing also the surrounding voltage field, to determine whether a fault has been transient or permanent. The presence of the voltage field will also reset the Pathfinder 360 Alpha on restoration of HV supply. The instrument continuously monitors the residual current and voltage fields from the overhead line conductors and is triggered when it detects a fault current above the current/time threshold curve, passing in the line conductors. In the 'alarmed' state it will flash a super bright white LED, which can be seen over long distances at night as well as by day, to give local indication as well as triggering a dial up message to give a remote indication. A network fault can therefore be found by following the Pathfinders that have tripped, as it must lie between the last one to trip, and the first not to have tripped.

The standard model will automatically reset with restoration of the system voltage or it can be manually reset. There are, however, other models of the Alpha which will respond and reset according to the type of fault and system protection. The Pathfinder 360 Alpha is powered by a Long Life Lithium Thionyl Chloride battery, which provides over 600 flashing hours during its anticipated 10 year operating life. To maintain sufficient power throughout this lifetime, the instrument wakes up in response to an event. This event can either be the sensing of a fault current or the reporting of status at a pre-set regular interval. The instrument cannot be polled or interrogated.

2.0 MODEL FEATURES

ENVIRONMENTAL

The body and lens of the Pathfinder 360 Alpha case is a single polycarbonate moulding with an 'O' ring sealed polycarbonate screw cap, giving an IP rating greater than IP67. The 'O' ring is of Nitrile, which has high temperature and pressure resisting qualities, is fitted inside the screw cap to a high pressure withstand standard (BS 1806). This provides a high quality seal suitable for internal pressures caused by the combined effects of ambient temperature variations and the effects of solar heating. The integrity of the 'O' ring pressure seal has been type tested by pressurising the enclosure to 10 p.s.i.

PATHFINDER 360 ALPHA - MODEL TYPES

Type 'S' - main line permanent faults only.

Type 'D' - main line permanent, transient and intermittent faults

Type 'F' & 'FD' - all single or multiphase faults downstream of fuses

Type 'ROSCO' - incorporates a separate telecoms interface for a remote RTU.

PATHFINDER 360 ALPHA 'ROSCO'

The 'ROSCO' version has the addition of a transistor derived alarm output in the form of N/O N/C signal. The relay follows the bright red LED in terms of operation. All the above models may be a ROSCO version.

3.0 OPERATION

3.1 MONITORING RESIDUAL FIELD - AUTO-GAIN

The Pathfinder 360 Alpha incorporates an Auto-Gain feature which enables the instrument to continuously monitor the residual electromagnetic field from the conductors. The residual field will vary as the load changes and according to line geometry. The Auto-gain compensates for these variations, so that it sees a zero field, until a fault interrupts the field. In this way Pathfinder may react to small increases in magnetic field, as a result of low values of fault current.

3.2 MAGNETISING CURRENT & FALSE INDICATIONS.

Bowdens has investigated exactly what electro-magnetic fields can be experienced both upstream and downstream during either an earth, or a phase to phase fault on an overhead line distribution network, and studied the decay time of these fields. We considered the out of balance of load currents, but also, where voltage fluctuations occur, high values of magnetising current which will flow to remote transformers, and may be interpreted by an FPI as fault current. Magnetising currents, however, contain no zero sequence component and so it is only the mathematical resultant from the physical phase separation to which an FPI will be sensitive.

3.3 FAULT SENSING

The Pathfinder 360 Alpha adjusts its sensitivity during the fault. The instrument will trip on an initial current setting of a nominal 12 Amps, after which it will go 'deaf' for 50msecs to allow magnetising currents and spikes to disperse. During this 'deaf' period the sensitivity is reduced to a nominal 300 Amps. As the fault progresses, the sensitivity increases, so at the end of the 'Instantaneous' phase of protection clearance, the sensitivity will be at a nominal 25 Amps after 150mSecs. It then is looking for 'Earth Faults' cleared on IDMT before 550mSecs after which it moves into the final SEF phase, increasing sensitivity to a nominal 10 Amps. In this way the Pathfinder mirrors the protection curve, so that low values of fault current have to be present on the network for over ½ seconds to be recognised by the Pathfinder as a genuine fault. This method of sensing has dramatically reduced the 'false tripping' as a result of system disturbances and spikes.

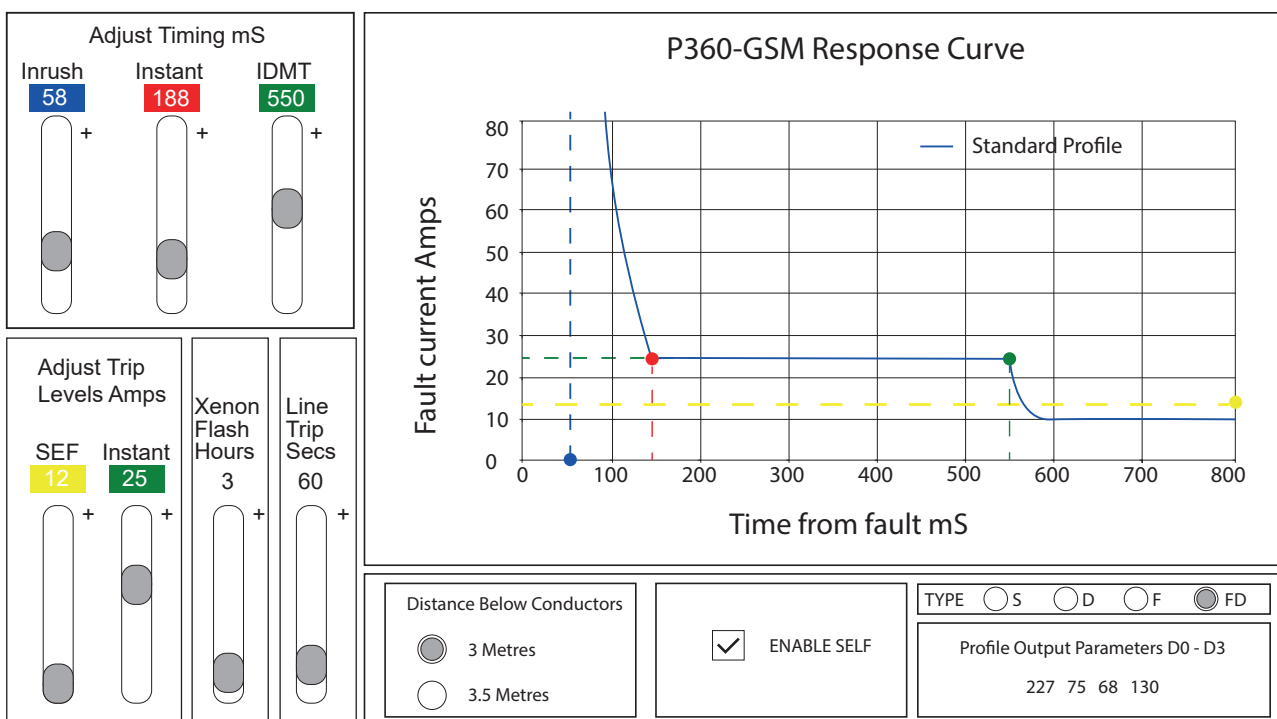

Fig. 1

Using our interactive XL spreadsheet, the values of current and time can be changed individually or set up as a profile. The profile can be downloaded at manufacture or downloaded remotely if the 2G & 4G option is employed through a recognised base station. The operating responses can therefore be tailored to the prevailing conditions, if the standard settings are not suitable.

3.4 PERMANENT OR TRANSIENT FAULT

The Pathfinder, having sensed the fault current on the response curve will wait for 30 seconds, to allow all switching activity to be completed, before it registers its voltage signal. If the Voltage signal is present, the fault is a Transient, if the Voltage is absent, the fault is permanent, and the instrument will respond accordingly (see Model Types - 2.0).

3.5 LOCAL INDICATION

The Pathfinder 360 Alpha super bright white LED will flash every three seconds with 360° visibility for three hours to indicate a permanent fault, or until HV line Volts are restored, which resets the indication. A second bright red LED will flash for 24 hours to indicate a transient fault, and remains flashing independent of restoration of line Volts.

3.6 COMMUNICATIONS 2G, 3G and 4G

The Pathfinder can be supplied with either a 2G or a 4G modem compatible with 2G, 3G and 4G according to availability and will operate on mobile telephone Private Networks or the public GSM or GPRS network. Various communication options are available including 2G quad band GSM for data-call and text messaging, GPRS to IP address on a private server or Web-page base station, or 4G for future proofing of available services.

3.7 BASE STATION OPTIONS

3.7.1 Direct to GE PowerOn Fusion SCADA. - A module is available from GE to accept messages from the Pathfinder and display the status on screen.

3.7.2 I-Host from Nortech Management - An established alarm data management software platform on which the Pathfinders can be operated.

3.7.3 Local stand alone PC - Powerwatch software can be loaded onto a stand alone PC and use a modem to receive and manage a group of the Pathfinders in a locality. This has an integration ability with top end SCADA systems.

3.7.4 Direct to Mobile telephone - Messages can be directed to 2 designated mobile telephones.

3.8 BASE STATION FUNCTIONALITY:

Receiver	Permanent Indication	Transient Indication	Trip Type	Status Report	RSSI	Low Batt	Change Remote Settings	Call Forward
GE PowerOn	Yes	Yes	Earth Fault IDMT SEF	Yes	Yes	Yes	Yes	No
Power watch local	Yes	Yes	Earth Fault IDMT SEF	Yes	Yes	Yes	Yes	Yes
I-HOST	Yes	Yes	No	Yes	Yes	Yes	Yes	Yes
Mobile phone	Yes	Yes	No	Yes	Yes	Yes	No	No

3.9 INSTRUCTIONS FOR USE

3.9.1 Mounting Bracket

The Pathfinder 360 Alpha is packaged and delivered as five instruments in a cardboard box. The aluminium bracket is fitted to the Pathfinder enclosure at the time of manufacture. If, for any reason the aluminium bracket is removed it should be reassembled ensuring the crinkled washer is under the bolt head and the solid washer is under the nut. DO NOT over tighten the nut. The bracket must be fitted with the sloping edge of the bracket facing down.

The Pathfinder 360 Alpha can also be supplied with magnetic mounts to aid removal/replacement. These magnetic mounts are available as either a factory fitted option or as a retrofit kit. A special pole mounted tool is also available from Bowdens to allow easy installation/removal of the Pathfinder 360 Alpha on the magnetic mount bracket.

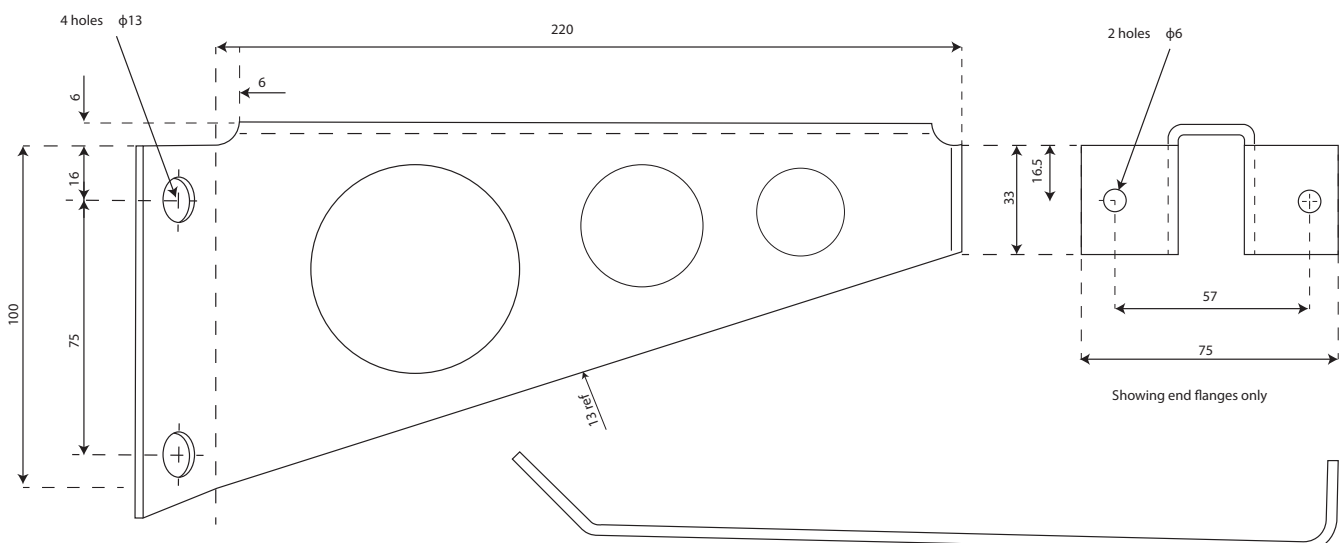

Dimensions shown in mm



Fig. 2

3.9.2 SIM CARD INSERT

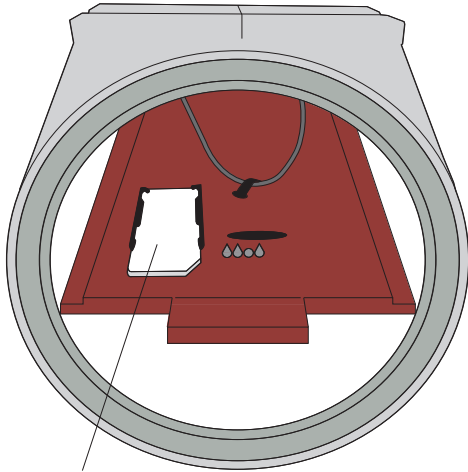

Sim card

Fig. 3

The SIM Card holder is on the leading edge of the PCB and easily accessed when the lid of the Pathfinder is unscrewed and the battery holder removed. Slide the SIM card into the holder with the chamfer towards the top of the SIM. Replace the battery holder.

3.9.3 BATTERY CONNECTION

The Pathfinder 360 Alpha Comms is supplied with the battery in place in the nylon holder but with the connector disconnected. Care should be taken when connecting the battery on site to prevent ingress of moisture. Unscrew the instrument cap. The battery connector is polarity sensitive, the red wire to the + on the PCB, but the three pins on the PCB must match the three females in the connector. Push the female connector firmly down onto the pins (Fig. 4).

Ensure that the matching 'O' ring surfaces are clean and dry with a smear of silicone grease over each. Replace instrument cap and screw down hand tight so that the alignment marker is in line with the centre of the anodised aluminium bracket (Fig. 5).

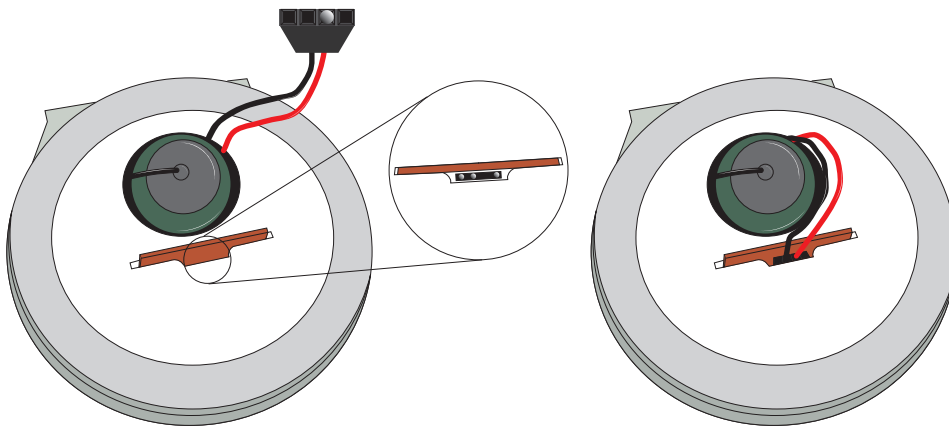

Fig. 4

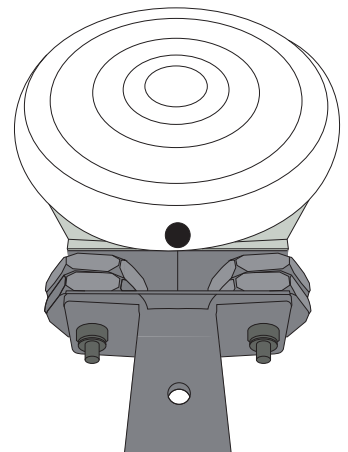

Fig. 5

3.10 COMMISSIONING PATHFINDER

The Pathfinder needs to be programmed with the telephone number of its SIM card, its identity, and the destination to which it needs to communicate. This destination can either be the telephone number of another modem or an IP address with the corresponding APN of the network to which it is connecting. Before the Pathfinder can be programmed it needs to be put into commissioning mode. **Commissioning must be carried out using a SIM enabled for a public APN.**



Place the magnet and hold stationary on the clear beacon lens at the centre of the arrow on the test label, and leave it in place whilst the green communication LED lights. When the red communication LED lights, take the magnet away. After approximately 30 seconds the green LED will start to flash, indicating that the Pathfinder is in commissioning mode, and ready to receive programming data. There are a number of ways the programming data can be sent, either from the base station or from the Bowdens website at www.faultwatch.com.

3.10.1 COMMISSION VIA WEBSITE:

To commission via the Bowdens website, you must first have purchased credits, against which you are given a username and password. On the internet, connect to www.faultwatch.com and enter your username and password in exactly the same format as it was supplied to you (all entries are case sensitive). In the product selection page choose the appropriate option.

Product Selection

Please select your instrument type and click Submit

Product Name	Mobile	BaseStation
MK10- GSM	<input type="radio"/>	<input type="radio"/>
P360- GSM	<input type="radio"/>	<input type="radio"/>
PowerWatch	<input type="radio"/>	<input type="radio"/>

For this document we shall only consider the Pathfinder 360 Alpha (P360) to a base station. Submit, and view the set up page. Select from the drop-down menu under 'Type of communications to use', either GSM if you are using 2G data call CSD protocol or GPRS if you are accessing an IP address.

Bowdens P360 - GSM Setup to Basestation

About your P360 - GSM Unit

Units SIM card telephone number
(Begin +44 for UK and leave out first 0)

Give your unit an identity
or enter serial number
(Up to 17 characters)

Type of communications to use

This option overrides the factory setting
for unit firmware versions v2.2 onwards.
(Earlier versions are fixed and ignore this option)

- SMS Text Message
- Data Call
- GPRS

HealthCheck Reporting

How often do you require
P360 to report its status?
(note for P360 Profile Units Click here)

Where to send your P360 report and alarm messages

Receiving Telephone number
(Begin +44 for UK and leave out first 0)

3.10.2 SMS or DATA CALL

Enter the telephone number of the Pathfinder SIM Card using the International +44 format followed by 10 digits. Enter the telephone number of the Base Station modem. Give your Pathfinder an identity (serial number) and select how often the status should be reported. This time should match the time entered on the Data Management software, so that the Pathfinder will generate a message to coincide with the software expecting to receive the heartbeat message. When you know the Pathfinder is in Commissioning mode press send to initiate the commission message. It will be confirmed at the mobile phone (for SMS applications) or at the P.C. or laptop from GSM applications.

3.10.3 GPRS

If the GPRS option is chosen, fields for the Server type and the Service Provider appear. The following details will need to be known before commissioning can take place.

Server Type: The IP address and the IP port of the Remote Server.

Service Provider details: Access Point Name (APN), Authentication User ID and Password and PDP (Packet Data Protocol) type.

When you know the Pathfinder is in commissioning mode (see 'Summary of Actions with Magnet') press send to initiate the commission message. It will be confirmed at the server.

Bowdens P360 - GSM Setup to Basestation

About your P360 - GSM Unit		Give your unit an identity or enter serial number <small>(Up to 17 characters)</small>	
Units SIM card telephone number <small>(Begin +44 for UK and leave out first 0)</small>	<input type="text" value="+447896573120"/>	<input type="text" value="1234"/>	
Type of communications to use		HealthCheck Reporting	
This option overrides the factory setting for unit firmware versions v2.2 onwards. <small>(Earlier versions are fixed and ignore this option)</small>	<input type="text" value="GPRS"/>	How often do you require P360 to report its status? <small>(note for P360 Profile Units Click here)</small>	<input type="text" value="7-Days"/>
Server Type	<input type="text" value="IHOST"/>	Service Provider Details	
Where to send your P360 report and alarm messages		Access Point Name (APN)	<input type="text" value="general.t-mobile.uk"/>
Remote Server IP Address	<input type="text" value="82.132.406.03"/>	Authentication User ID	<input type="text" value="auser"/>
Remote Server IP Port	<input type="text" value="5234"/>	Authentication Password	<input type="text" value="apassword"/>
		PDP Type	<input type="text" value="IP"/> <input type="button" value="Send"/>

TROUBLESHOOTING Communications LEDs

The expected sequence of the communications LEDs are:

Commissioning:	Waiting for Data: Data received Programmed:	Green Flashing Green and Red Out
Status:	Magnet Test:	Green - Green & Red - Out
Fault:	Magnet Test:	Green - Green & Red - Out Green & Red - Green - Out

SIM CARDS

More problems occur with SIM Cards than any other component that goes to make up the Pathfinder 360 Alpha system. The following are faults to look out for if your Pathfinder does not communicate as it should.

Is the SIM Card correctly installed within the modem or SIM Card reader?

Make sure the corner cut out matches the holder, and the plated connections are facing towards the PCB within the modem or reader.

Is the SIM Card activated? Is the telephone number issued correct?

It will not be possible to put the Pathfinder into commission mode (flashing green LED). Prove activation by putting the SIM card into a mobile phone and calling another mobile. If the call gets through it proves the SIM Card activation, and will give confirmation of the number.

Is the SIM Card PIN enabled?

The SIM Card should be PIN disabled or the PIN should be set to '0000'.

Does your SIM Card support Data-call or GPRS?

Not all cards will support Data-call or GPRS messages. Ensure that your SIM card is enabled for the correct communications type. Check with your SIM Card supplier if in doubt.

Has your SIM Card got any Credit if it is 'pay as you go'?

Check credit on SIM Card.

Are the telephone numbers entered correctly on the base station?

Check the numbers, and make sure that they are entered as local calls for the base station, but in international format if commissioned from the website.

Does your local service provider support calls from a U.K. based server?

In certain parts of the world some local network providers do not support this service. Either talk to your local network provider, or change providers for this application. Using the POWERWATCH software to commission units involves only local calls. If a local mobile to mobile telephone call works then a Pathfinder to Base station call will work.

4.0 POWER SUPPLY

Battery

A SAFT LSH20 3.6 V 14Ah R20 (D size) lithium thionyl chloride primary cell is used to give the following performance.

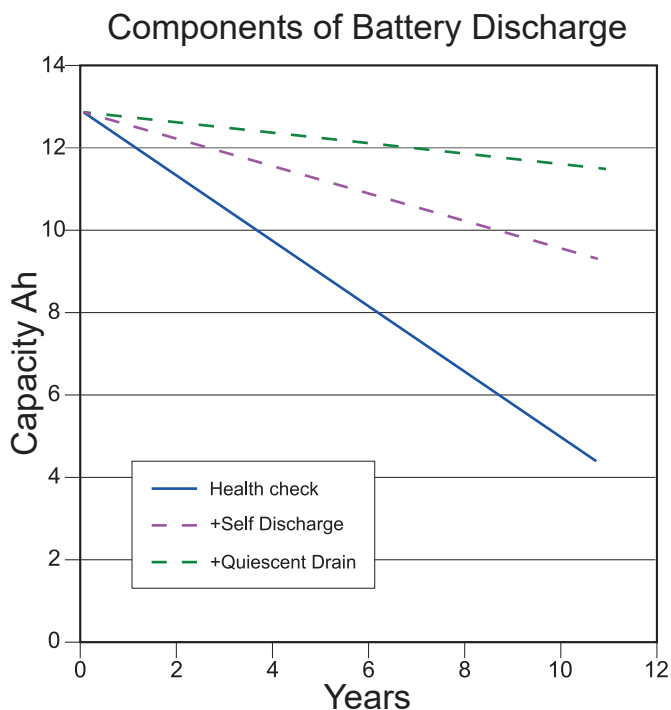

Fig. 6

Designed for a 10 year life under the following conditions:

- Average temperature 16°C giving average self discharge of 2% remaining capacity per annum.
- Weekly health check message of 20 seconds at 350 mA average current.
- Quiescent drain is 40 micro Amps typical.
- Gives over 400 flashing hours with Comms Option.
- Gives over 600 hours without Comms Option.

LITHIUM BATTERIES - SAFE HANDLING

Lithium cells are very high energy systems and as such should be treated with respect. However, cells are designed with a safety vent, which will allow the quiet release of electrolyte under conditions of abuse. To ensure the trouble free use of lithium batteries, the following safety considerations must be observed:

1. TEMPERATURE

Cells and batteries should not be exposed to temperatures in excess of 80°C.

2. FUSES

Lithium multi-cell batteries are fused by the manufacturer. In some batteries a replacement fuse may be fitted.

NOTE: UNDER NO CIRCUMSTANCES SHOULD THE FUSE BE REPLACED BY A HIGHER RATED FUSE OR A FUSE BY-PASSED.

If in doubt about replacing fuses, contact the battery manufacturer. Particular care should be taken that unfused single cells are not overloaded or shorted.

3. DISCHARGING

Do not attempt to discharge a lithium cell or battery at a greater rate than that recommended by the manufacturer. Do not force the discharge of single cell or multi-cell batteries as this may result in overheating.

4. DO NOT CHARGE

Never attempt to charge a lithium cell or battery. In the event of accidental charging, the cell or battery may overheat and vent.

5. MULTI-CELL BATTERIES

Do not use single cells to make up a multi-cell battery. If a multi-cell battery is required, consult with the manufacturer who will design and supply to specification.

6. DESTRUCTION

Do not open, puncture, crush or tamper with the cells or batteries as this will release the electrolyte and also expose materials which are potentially flammable.

7. CONTAINERS

Never use lithium cells or batteries in a completely sealed pressure container. A suitable relief device must be incorporated in the container.

8. PRECAUTIONS

In the event that a cell or battery is accidentally shorted or starts to heat up, it should be disconnected immediately and removed to the outdoors or to a well ventilated area to cool down, taking care to protect personnel and surroundings. Once stabilised to a safe condition, the cell or battery can be disposed of in the normal manner. Suitable protective clothing should be worn when handling suspect cells/batteries. If the skin has come into contact with the electrolyte, it must be washed with water.

9. DISPOSAL

Cell and batteries must be disposed of by a licensed disposal specialist. A certificate is issued following correct disposal. **DO NOT DISPOSE OF IN A FIRE.**

10. COSSH

Information is available from the battery manufacturer in connection with COSSH. Further information is also available from the battery manufacturer on battery safety and handling.

5.0 INSTALLATION LOCATION

Ideal Locations for the Pathfinder to be installed.

Conductor formation

Flat, triangular and wishbone formation lines.
Three phase or single phase circuits.
Open radial feeders only.

Poles

Wood poles or concrete pole lines.
Clean, single circuit, intermediate poles.
Angle section poles with stay wire.

Types of Protection

Solidly earthed or resistance earthed networks.
Compensated networks depending upon the set-up.

POSITION ON POLE

The Pathfinder 360 Alpha must be placed directly below and in line with the centre phase conductor and about three metres from the lowest conductor. It should be in the same relative position on single phase lines. The indicator can face either up or downstream depending on the best line of vision from the likely viewing point.

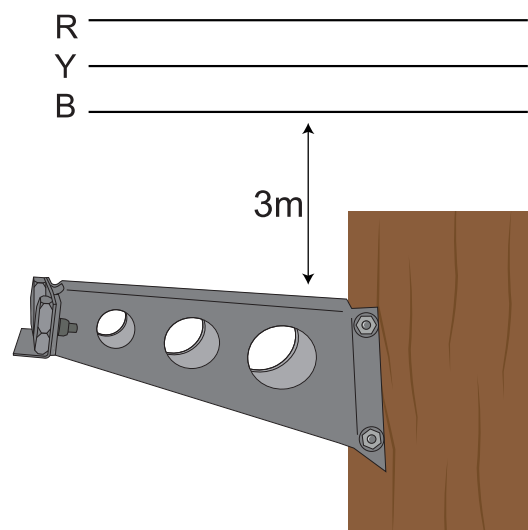

Fig. 7

WHERE NOT TO USE

The Pathfinder 360 Alpha indicators should not be used on poles in the following situations:

- a) with underground cables running up the pole.
- b) with transformers on the pole
- c) with tee off lines
- d) in close proximity (within 50m) to other HV lines
- e) vertical formation lines
- f) closed ring circuits
- g) poles supporting underslung earth wires, telecoms circuits and low voltage power lines.

6.0 TEST SPECIFICATIONS

ELECTROMAGNETIC COMPATIBILITY

The Pathfinder 360 Alpha has been fully EMC tested to the following standards:

BS EN 50081-1 : 1992 Generic emissions standard (Heavy industrial) - none detected

BS EN 50082-2 : 1992 Generic immunity standard (Heavy industrial)

To IEC 801-2 :1991 Electrostatic discharge
Standard requirement - Air 4KV, Contact 8KV
Actual testing completed - Air 4KV, Contact 15KV

IEC 801-3 :1984 Radiated Electromagnetic Fields.
27MHz - 1GHz @ 15V/M
Standard requirement 10V/M

IEC 801-4 :1988 Fast Transient/Bursts
Standard requirement +/- 1KV
Actual testing completed +/- 4KV

ENVIRONMENTAL – BS EN 60068

The Pathfinder is housed in a factory sealed water proof housing that has been pressure tested to 10 p.s.i. Nitrile 'O' ring to B.S. 1806 : 1989 'Specification for toroidal sealing rings and their housings.'

TEMPERATURE TESTS – IEC60943 : 1998

Temperature function tests have been carried out on a representative Pathfinder 360 Alpha instrument between the temperature range -50°C and +80°C. The tests demonstrated stability of operation of the instrument for both Earth Fault and instantaneous threshold trip levels against temperature. Operational stability was also demonstrated through the temperature range for the 40msec 'DEAD' time and the electrostatic field. A full report is available on request.

VIBRATION ENDURANCE TESTING – BS EN 60068

Three Pathfinder 360 Alpha instruments in different attitudes, were bolted to a section of 11KV wood pole which was mounted on the jig of a Vibration Machine Table. A resonant frequency was established for the set up and Vibration Endurance Tests carried out for a period of 24 hours. A full report is available on request.

IMPACT TESTING – BS EN 60068

A standard impact test rig, with a pivoted weight, was used to impart a force of two Joules on any part of the Pathfinder 360 Alpha instrument casing. A full report is available on request.

IMPACT TESTING - AIRGUN TESTS

Tests were carried out using a 0.22 BSA air-rifle. Multi-hits at six metres from the lens did not cause damage to the polycarbonate casing. The tests demonstrated that at three metres from the conductors the Pathfinder is ideally positioned to minimise the impact effects of air gun pellets. A full report is available on request.

PATHFINDER CASING CHEMICAL RESISTANCE

Detail of the chemical resistance of the materials used in Pathfinder casing is available on request. The casing is manufactured to our specification of polycarbonate, which includes an ultra violet inhibitor. The lid is manufactured from UPVC, which also has a high degree of resistance to chemical action.

7.0 ROUTINE TESTING

FUNCTION & BATTERY TEST

A suitable bar magnet must be used, ideally 25 x 15 x 5 mm supplied with the Pathfinder. Hold the magnet stationary on the clear beacon lens at the centre of the arrow on the test label. When the magnet is applied in this position, the bright red LED within the beacon lens will light for three to four seconds and then reset, during which time the bright white LED will flash once. This indicates a healthy battery. If the magnet is left in this position the bright white LED will begin to flash. The communications green LED will light, followed by red. Repeat the operation with the magnet to reset the comms LEDs.

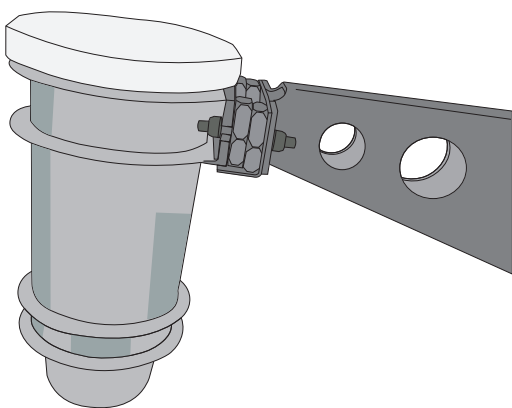

NOTE: All the actions below must be carried out away from the influence of any voltage fields or any electro-magnetic fields. An office environment with computers and fluorescent light will produce electromagnetic fields that can interfere with the Pathfinder.

Fig. 8

'A' - Pathfinder viewed from underside

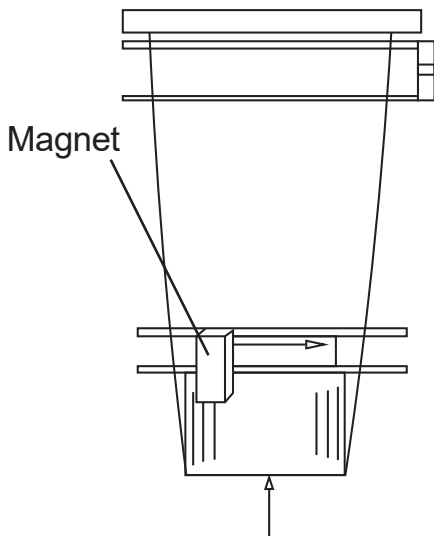

'A' - Pathfinder viewed from underside

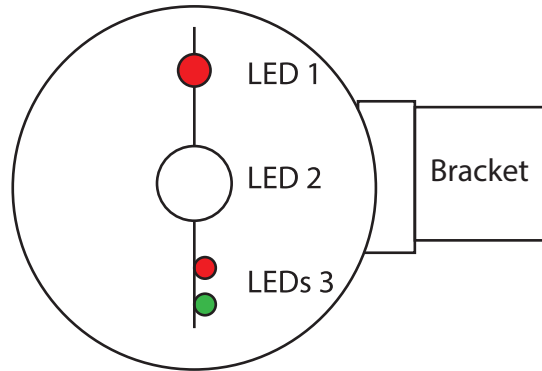

LED 1 Transient Fault Indicating red LED

LED 2 Main Ultra Bright white LED

LEDs 3 Communications LEDs - Green & Red

Fig. 9

8.0 SPECIFICATION

Line Voltage	- 6KV to 36KV
Installation	- 3 metres from lowest conductor and positioned directly below the centre phase facing towards or away from source of supply
Instrument Material	- Polycarbonate body with UPVC screw lid and Nitrile 'O' ring Sealed enclosure to IP67.
Phase to Phase and Earth Faults	- All current levels above 12 Amps
Sensitive Earth Fault level	- Minimum sensitivity 7 Amps
Live/dead line Trip Level	- 7 - 20 Amps depending on Automatic Gain Control.
Initial time delay	- 40 msecs
Voltage reset time	- 60 seconds
Temperature Range	- -25°C to + 70°C
Humidity	- 0-100%
Sampling Rate	- Continuous full wave sampling
Quiescent drain	- 40uA nominal
Bright white LED	- 360 degree visibility.
Energy	- 0.24 joules of flash
Flash rate	- 10 - 12 seconds between flashes
Power demand	- 15mAh 3hrs = 45mAh
Bright red LED	- 3000 mili candela (normal LED 18 mili candela)
Power demand	- 25mA pulsed 40mS every 1.6 seconds.
	- 0.65mAh 24hrs = 16mAh
Battery	- 1 x Lithium Thionyl Chloride 14Ah - D cell
Battery Life	- 10 years at 20 degrees C. Shelf life 10 years (nom)
Flash Rate	- 10/15 second intervals
Reset time	- 3 hours standard (6 hours optional)
Flashing Capacity	- up to 600 hours nominal at 20 degrees C

The Pathfinder 360 Alpha - Standard Bracket Version

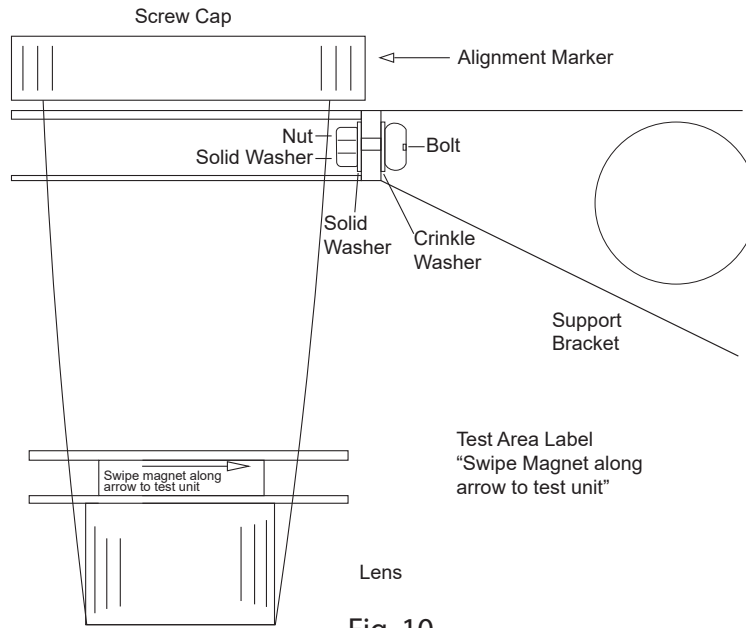

Fig. 10

The Pathfinder 360 Alpha - Mag Mount Version

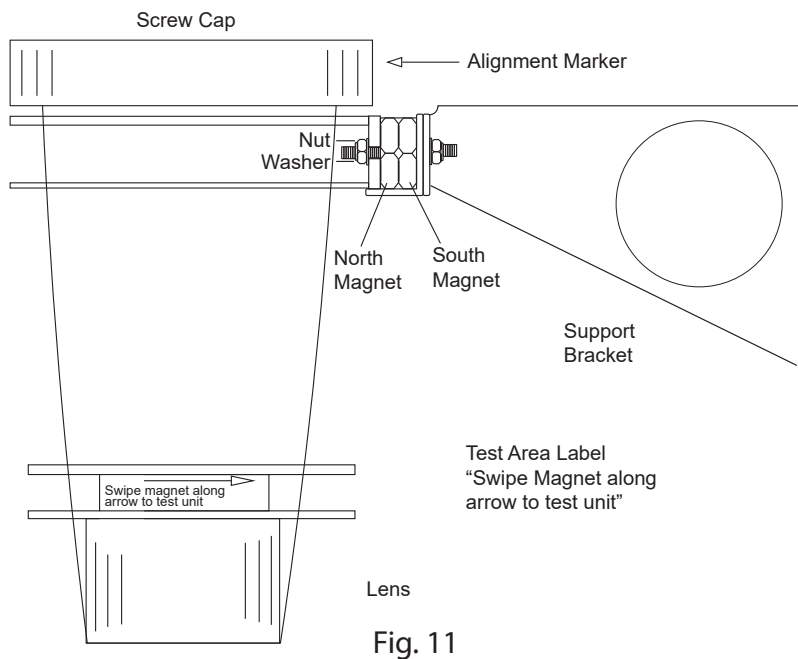

Fig. 11

Maintain 90 degree angle when fitting to pole

Plan View

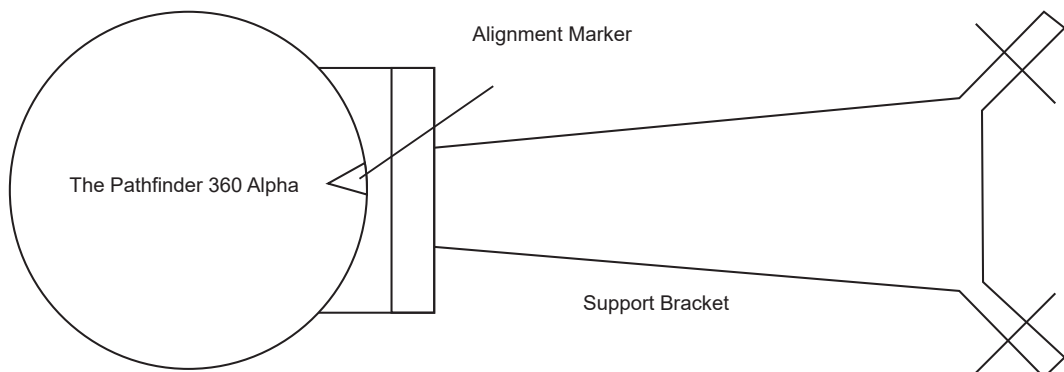

Fig. 12

The Pathfinder 360 Alpha- Type Selection Guide

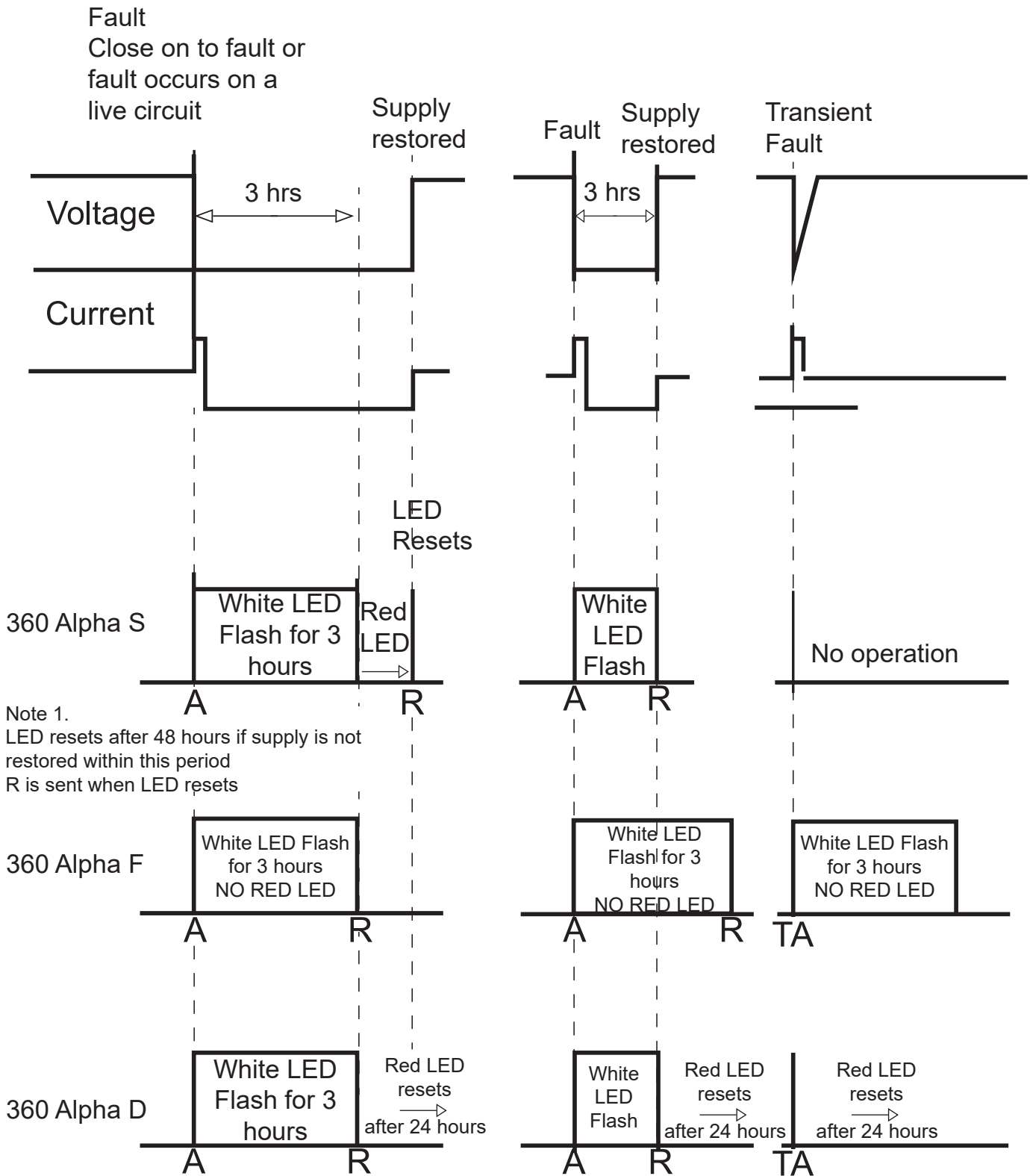

Fig. 13

GSM Messages

- A = Permanent Alarm
- TA = Transient Alarm
- R = Reset



Please consider the environment at the end of this product's life.

At end of life please take this unit to your closest electrical recycling point.
or
Return this unit to Spring (Europe) Limited for recycling.

Recycle Responsibly
ISO14001

VERSION 2.1

RELEASE 29.05.2026

ECO Reference	Date
ECO0371	01.09.25
ECO0457	29.05.26